

73-300 SERIES

Carbon Steel Double Union End Ball Valve

Threaded, 3000 CWP (psig), Cold Non-Shock.
150 psig Saturated Steam.
Vacuum Service to 29 inches Hg.
MSS SP-110 compliant.



FEATURES

- Heavy duty quarter turn lever
- Reinforced seats and seals
- Steel barstock design
- Easy installation and maintenance
- Blow-out-proof stem design
- Adjustable packing gland
- Zinc phosphate corrosion protection

VARIATIONS AVAILABLE:

73-340 Series (316 SS Ball & Stem)

UL LISTINGS @ 250 PSIG MAX.

- Guide YRPV: Gas shutoff valve for use with natural and manufactured gases.
- Guide YSDT: LP gas shutoff valve.
- Guide YRBX: Flammable liquid shutoff valve.

Note: Listings apply ONLY to the standard -01 valves.

OPTIONS AVAILABLE: (More information in Section J)

(SUFFIX)	OPTION	SIZES
-01	Standard Configuration	All
-P -01	BSPP (Parallel) Thread Connection	1/4" to 2"
-T -01	BSPT (Tapered) Thread Connection	1/4" to 2"
-02-	Stem Grounded	1/4" to 2"
-07-	Steel Tee Handle	1/4" to 1.5"
-08-	90° Reversed Stem	1/4" to 2"
-14-	Side Vented Ball (Uni-Directional)	1/4" to 2"
-15-	Wheel Handle, Steel	1/4" to 1"
-18-	Plain Yellow Grip	1/4" to 2"
-19-	Lock Plate	1/4" to 2"
-21-	UHMWPE Seats (Non-PTFE)	1/4" to 2"
-22-	Viton Union Seals	1/4" to 2"
-29-	Graphite Packing & Seals	1/4" to 2"
-45-	Less Lever & Nut	1/4" to 2"
-60-	Grounded Ball & Stem	1/4" to 2"
-63-	Threaded x Socket Weld	1/2" to 2"
-64-	250# Steam Trim	1/4" to 2"

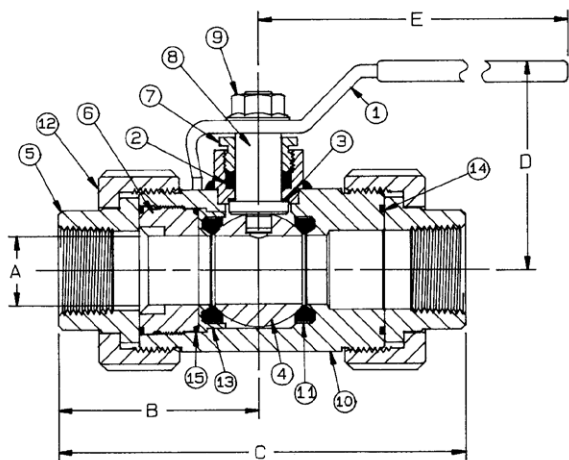

STANDARD MATERIAL LIST

PART	MATERIAL
1 Lever and grip	Steel, zinc plated w/vinyl
2 Stem packing	RPTFE
3 Stem bearing	RPTFE
4 Ball	ASTM A276, Type 316 Stainless Steel
5 Tailpiece (2)	A108-CS
6 Retainer	A108-CS
7 Gland nut	A108-CS
8 Stem	ASTM A108, CS, zinc phosphate finish or ASTM A276, Type 316 Stainless Steel
9 Lever nut	Steel, zinc plated
10 Body	A108-CS
11 Seat (2)	RPTFE
12 Union nut (2)	A108-CS
13 Seat holder	A108-CS
14 Union seal (2)	RPTFE
15 Retainer seal	RPTFE

PRODUCT NUMBER	SIZE	A	B	C	D	E	WT.
73-301-01	1/4"	0.43	2.50	5.00	2.50	5.62	3.51
73-302-01	3/8"	0.57	2.50	5.00	2.50	5.62	3.45
73-303-01	1/2"	0.62	2.50	5.00	2.50	5.62	3.35
73-304-01	3/4"	0.81	2.71	5.31	2.62	5.62	4.48
73-305-01	1"	1.00	2.96	6.06	3.12	6.62	7.04
73-306-01	1.25"	1.25	2.87	6.12	3.43	8.00	9.96
73-307-01	1.5"	1.50	3.46	7.12	3.56	8.00	14.83
73-308-01	2"	1.75	3.75	7.50	4.18	9.00	20.50

FOR PRESSURE/TEMPERATURE RATINGS, REFER TO PAGE M-15, GRAPH NO. 15



FLOW DATA

For Apollo® Ball Valves

The listed Cv "factors" are derived from actual flow testing, in the Apollo® Ball Valve Division, Conbraco Industries, Inc., Pageland, South Carolina. These tests were completed using standard "off the shelf" valves with no special preparation and utilizing standard schedule 40 pipe. It should be understood that these factors are for the valve only and also include the connection configuration. The flow testing is done utilizing water as a fluid media and is a direct statement of the gallons of water flowed per minute with a 1 psig pressure differential across the valve/connection unit. Line pressure is not a factor. Because the Cv is a factor, the formula can be used to estimate flow of most media for valve sizing.

FLOW OF LIQUID

$$Q = C_v \sqrt{\frac{\Delta P}{SpGr}}$$

$$\text{or } \Delta P = \frac{(Q)^2 (SpGr)}{(C_v)^2}$$

Where:

Q = flow in US gpm
 ΔP = pressure drop (psig)
 SpGr = specific gravity at flowing temperature
 Cv = valve constant

FLOW OF GAS

$$Q = 1360 C_v \sqrt{\frac{(\Delta P) (P_2)}{(SpGr) (T)}}$$

$$\text{or } \Delta P = \frac{5.4 \times 10^{-7} (SpGr) (T) (Q)^2}{(C_v)^2 (P_2)}$$

Where:

Q = flow in SCFH
 ΔP = pressure drop (psig)
 SpGr = specific gravity (based on air = 1.0)
 P₂ = outlet pressure-psia (psig + 14.7)
 T = (temp. °F + 460)
 Cv = valve constant

Cv FACTORS FOR APOLLO VALVES

SIZE (IN.)	1/4	3/8	1/2	3/4	1	1.25	1.5	2	2.5	3	4	6	8	10	12
VALVE															
32-100/200 Series	5.1	6.6	8	24	30	45	55	95	--	--	--	--	--	--	--
64-100/200 Series	6	7	19	34	50	104	268	309	629	1018	1622	--	--	--	--
64W Series	--	--	--	--	--	--	--	--	629	1018	1622	--	--	--	--
70B-140 Series	8.4	7.2	15	30	43	48	84	108	190	370	670	--	--	--	--
70-100/200 Series	8.4	7.2	15	30	43	48	84	108	190	370	670	--	--	--	--
70-300/400 Series	--	--	15	30	43	48	84	108	--	--	--	--	--	--	--
70-600 Series	2.3	4.5	5.4	12	14	21	34	47	--	--	--	--	--	--	--
70-800 Series	8.4	7.2	15	30	43	48	84	--	--	--	--	--	--	--	--
71AR Series	--	--	--	30	43	48	84	108	190	370	--	--	--	--	--
71-100/200 Series	--	--	--	30	43	48	84	108	190	370	--	--	--	--	--
72-100/900 Series	--	--	26	48	65	125	170	216	--	--	--	--	--	--	--
73A-100 Series	8.4	7.2	15	30	43	48	84	108	--	--	--	--	--	--	--
73-300/400 Series	--	--	26	48	65	125	170	216	--	--	--	--	--	--	--
74-100 Series	8.4	7.2	15	30	43	48	84	108	190	370	670	--	--	--	--
75-100 Series	8.4	7.2	15	30	43	48	84	108	190	370	670	--	--	--	--
76AR Series	8.4	7.2	15	30	43	48	84	108	190	370	670	--	--	--	--
76F-100 Series	8.1	15	15	51	68	125	177	389	--	--	--	--	--	--	--
76-100 Series	8.4	7.2	15	30	43	48	84	108	190	370	--	--	--	--	--
76-300/400 Series	--	--	26	48	65	125	170	216	--	--	--	--	--	--	--
76-600 Series	2.3	4.5	5.4	12	14	21	34	47	--	--	--	--	--	--	--
7K-100 Series	--	--	15	51	68	125	177	389	503	--	--	--	--	--	--
77AR Series	8.1	15	15	51	68	125	177	389	--	--	--	--	--	--	--
77C-100/200 Series	4.5	7.2	16	36	68	125	177	389	503	--	--	--	--	--	--
77D-140 Series	4.5	7.2	16	36	68	125	177	389	--	--	--	--	--	--	--
77D-640 Series	--	--	--	11	24	35	--	--	--	--	--	--	--	--	--
77G-UL Series	4.5	7.2	16	36	68	125	177	389	503	--	--	--	--	--	--
77W Series	--	--	16	36	68	125	177	389	--	--	--	--	--	--	--
77X Series	--	--	16	36	68	--	--	--	--	--	--	--	--	--	--
77-100/200 Series	8.1	15	15	51	68	125	177	389	503	--	--	--	--	--	--
79 Series	8.5	8.5	9.8	32	44	66	148	218	440	390	--	--	--	--	--

continued on next page



FLOW DATA

For Apollo® Ball Valves

Cv FACTORS FOR APOLLO VALVES (continued from page M-3)

SIZE (IN.)	1/4	3/8	1/2	3/4	1	1.25	1.5	2	2.5	3	4	6	8	10	12
VALVE															
80/81 Series	8.4	7.2	15	30	43	48	84	108	190	370	--	--	--	--	--
82-100/200 Series	8.1	14	26	51	68	120	170	376	510	996	1893	--	--	--	--
83A/83B Series	8.1	14	26	51	68	120	170	376	--	--	--	--	--	--	--
83R-100/200 Series	--	--	--	--	--	--	170	376	--	996	1893	--	--	--	--
86A/86B Series	8.1	14	26	51	68	120	170	376	--	--	--	--	--	--	--
86R-100/200 Series	--	--	--	--	--	--	170	376	--	996	1893	--	--	--	--
87A-100 Series	--	--	--	--	--	--	86	104	234	375	673	1099	1902	3890	--
87A-200 Series	--	--	15	19	75	--	195	410	545	1021	2016	4837	9250	15170	22390
87A-700 Series	--	--	--	--	--	--	86	104	234	375	673	1099	1902	3890	--
87A-900 Series	--	--	15	19	75	--	195	410	545	1021	2016	4837	9250	15170	22390
87B-100 Series	--	--	--	--	--	--	--	--	--	375	673	1099	1902	3890	--
88A-100 Series	--	--	--	--	--	--	86	104	234	375	673	1099	1902	3890	--
88A-200 Series	--	--	15	19	75	--	195	410	545	1021	2016	4837	9250	15170	22390
88A-700 Series	--	--	--	--	--	--	86	104	234	375	673	1099	1902	3890	--
88A-900 Series	--	--	15	19	75	--	195	410	545	1021	2016	4837	9250	15170	22390
88B-100 Series	--	--	--	--	--	--	--	--	--	375	673	1099	1902	3890	--
89-100 Series	8.4	7.2	15	30	43	48	84	108	190	370	--	--	--	--	--
9A-100 Series	8.3	6.7	5.7	10	16	25	40	62	--	--	--	--	--	--	--
91-100 Series	8.3	6.7	5.7	10	16	25	40	62	--	--	--	--	--	--	--
92-100 Series	8.3	6.7	5.7	10	16	25	40	62	--	--	--	--	--	--	--
93-100 Series	8.3	6.7	5.7	10	16	25	40	62	--	--	--	--	--	--	--
94A-100/200 Series	6	7	19	34	50	104	268	309	629	1018	1622	--	--	--	--
95-100/200 Series	--	--	15	51	68	--	--	--	--	--	--	--	--	--	--
95A-300/400 Series	--	--	19	34	50	--	--	--	--	--	--	--	--	--	--
96-100 Series	8.3	6.7	5.7	10	16	25	40	62	--	--	--	--	--	--	--
399-100 Series	8.4	7.2	15	30	43	48	84	108	190	370	--	--	--	--	--
489-100 Series	8.4	7.2	15	30	43	48	84	108	190	370	--	--	--	--	--

PRESSURE TEMPERATURE RATINGS

3000# CS (GRAPH 15)

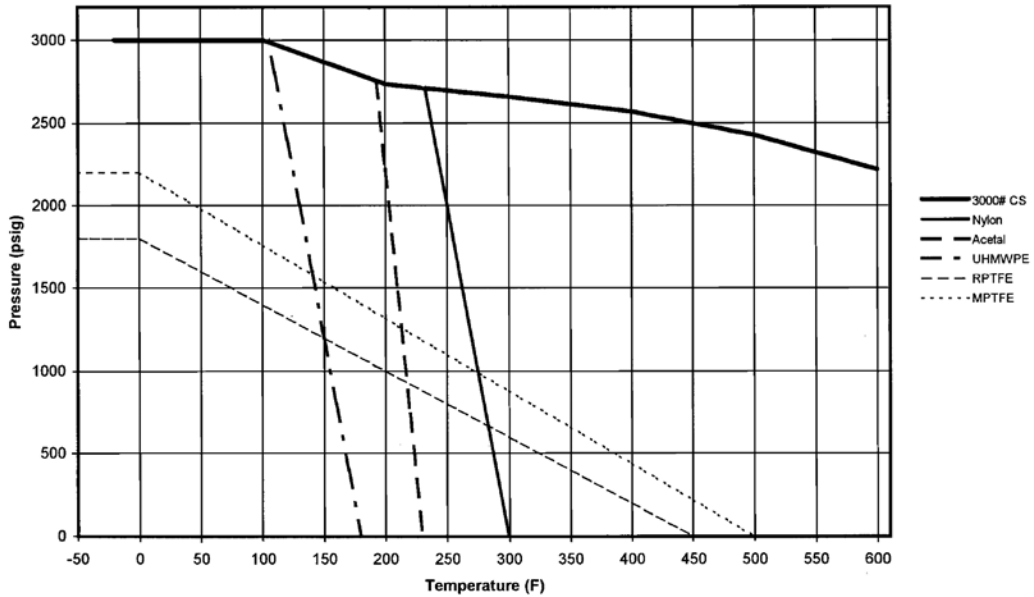

Refrigeration Valve (GRAPH 16)

